



2/12 Stanley Street WALLAN VIC

3 2 2

Wilson Partners Real Estate is proud to present 2/12 Stanley Street, Wallan.

A stylish and low maintenance townhouse perfectly positioned for relaxed everyday living.

Nestled in a quiet and well established pocket of Wallan, this contemporary residence offers the ideal blend of comfort, functionality, and convenience, making it an outstanding opportunity for first home buyers, downsizers, and savvy investors.

Designed with practicality in mind, the home features a spacious master bedroom complete with walk in robe and private ensuite, while the remaining bedrooms are fitted

Type : Unit
Price : \$465,000 - \$510,000
Land Size : 257 sqm
View : <https://www.wilsonpartners.com.au/8700251>



Riley Evans
0418968815



Georgina Smith
0490663721

[For full version visit the website](https://www.wilsonpartners.com.au)



Ground Floor

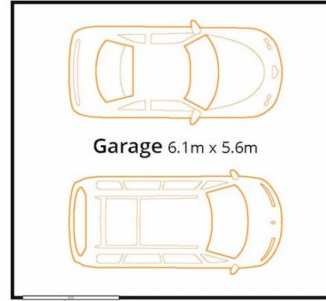

(Not In Position)

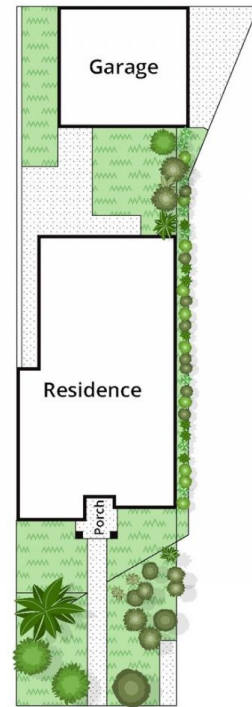

Site Plan



Whilst bwrn.com.au has made every attempt to ensure the accuracy of the floor plan contained here, measurements are approximate and no responsibility is taken for any error, omission, or mis-statement. This plan is for illustrative purposes only.

2/12 Stanley Street, Wallan

Wilson Partners | Who Sold It?®